

# UV GLASS BONDING ELEMENTS

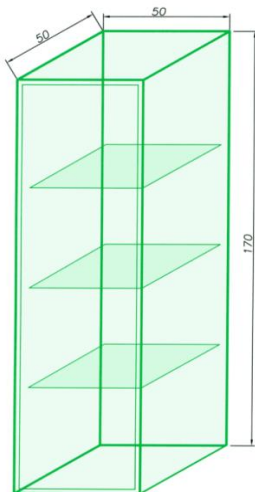

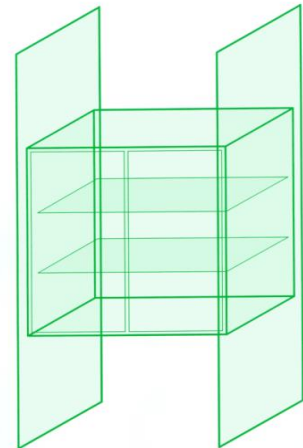

**1704.10**

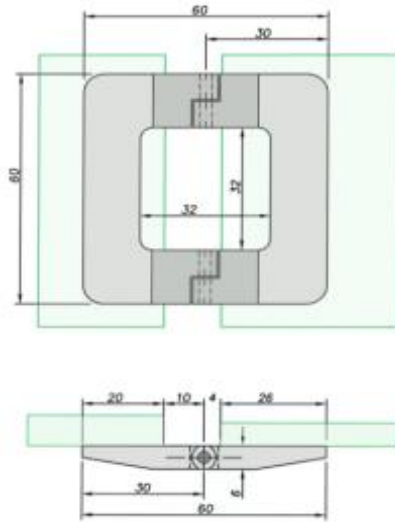
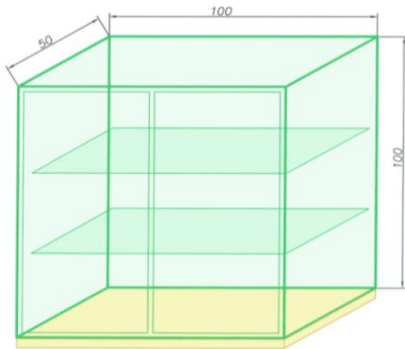

**1704.11**

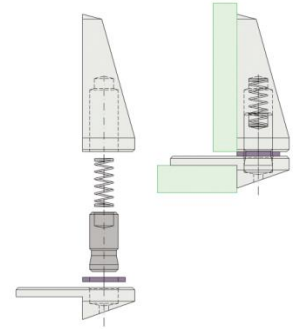
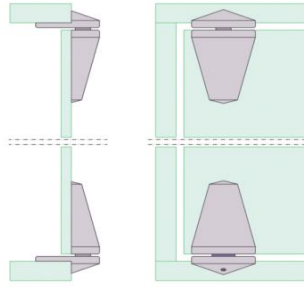

**GLA-Fix- Swing Hinge, Glass-to-Glass**

Swing Hinges for UV bonding are made of stainless steel and designed for glass showcase doors. Two part top and bottom hinge is UV bonded to glass, up to 12mm (1/2") thick, glass. Spring loaded axle at the bottom hinge allows the door to be easily installed and uninstalled. Maximum door opening angle: 180°.

CODE	DESCRIPTION	SIZE
1704.10	Top Swing hinge, Glass-to-Glass,	Ø25mm
1704.11	Bottom Swing hinge, Glass-to-Glass,	Ø25mm



**1704.20**



**1704.21**

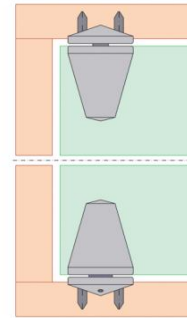
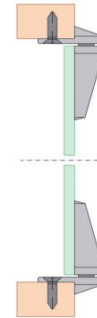
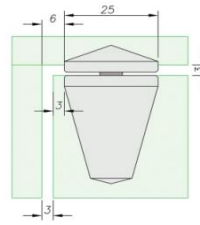
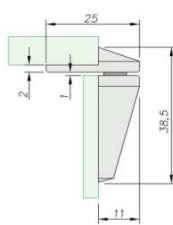

**GLA-Fix -Swing Hinge, Glass-to-Wood**

Swing Hinges for UV bonding are made of stainless steel and designed for glass showcase doors. Two part top and bottom hinge is UV bonded to glass, up to 12mm (1/2") thick, glass. Spring loaded axle at the bottom hinge allows the door to be easily installed and uninstalled. Maximum door opening angle: 180°.

CODE	DESCRIPTION	SIZE
1704.20	Top Swing hinge, Glass-to-Wood,	Ø25mm
1704.21	Bottom Swing hinge, Glass-to-Wood,	Ø25mm



**1710.10** Ø40mm



**1711.10** Ø25mm

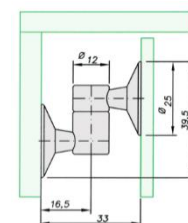
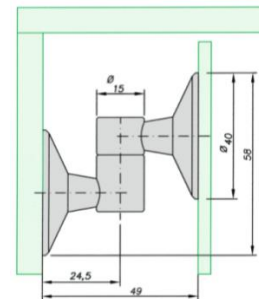

**GLA-Fix Conic Hinge, Glass-to-Glass ,**

Conic Hinges for UV bonding are made of stainless steel and designed for glass showcase doors. Top and bottom hinge is UV bonded to glass. Large type up to 12mm (1/2") thick, and Small type up to 10mm (3/8") thick glass. The hinges can be bonded to side panels both from inside and outside. Maximum door opening angle: 180°.



**1710.20** Ø40mm      **1711.20** Ø25mm

**GLA-Fix Conic Hinge, Glass-to-Glass ,**

Stainless steel and designed for glass showcase doors. Top and bottom hinge is UV bonded to glass. Large type up to 12mm (1/2") thick, and Small type up to 10mm (3/8") thick glass. The hinges can be bonded to side panels inside and outside. Max. door opening angle: 180°.



**1645.10** Ø40mm      **1645.11** Ø25mm

**GLA-Fix Conic Hinge, Glass-to-Glass**

Stainless steel, Large type up to 12mm (1/2") thick, and Small type up to 8mm (5/16") thick glass. Hinges can be fixed to side panels both from inside and outside. Maximum door opening angle: 180°.

**GLA-Fix Wing Hinge, Glass-to-Glass**

Wing Hinges for UV bonding are made of Aluminium and designed for glass showcase doors. Top and bottom hinge is UV bonded to glass. Hinges are ordered for left hand and right hand doors. Maximum glass thickness: 8mm, Max. door opening angle: 180°.



**CODE DESCRIPTION**

**1715.10** Right hand Square Wing hinge, Glass-to-Glass,  
**1715.11** Left hand Square Wing hinge, Glass-to-Glass,

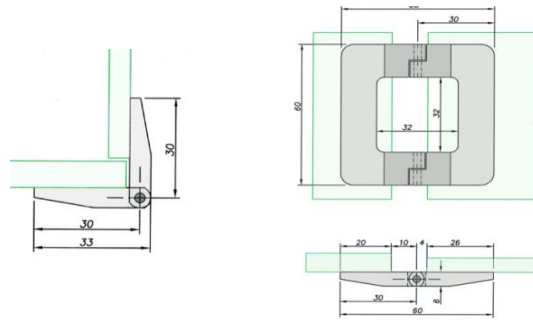

**CODE DESCRIPTION**

**1717.10** Right hand Curved Wing hinge, Glass-to-Glass,  
**1717.11** Left hand Curved Wing hinge, Glass-to-Glass,

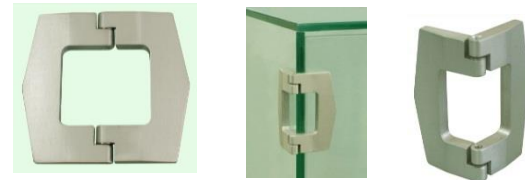

**CODE DESCRIPTION**

**1716.10** Right hand Angle Wing hinge, Glass-to-Glass,  
**1716.11** Left hand Angle Wing hinge, Glass-to-Glass,

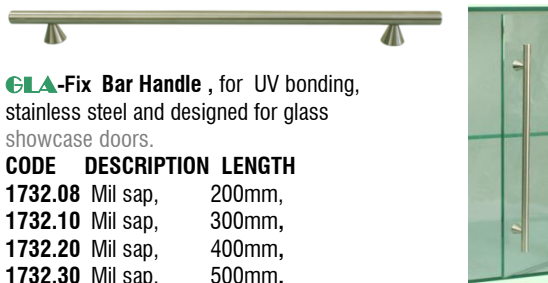

**GLA-Fix Bar Handle** , for UV bonding, stainless steel and designed for glass showcase doors.

**CODE DESCRIPTION LENGTH**

**1732.08** Mil sap, 200mm,  
**1732.10** Mil sap, 300mm,  
**1732.20** Mil sap, 400mm,  
**1732.30** Mil sap, 500mm,



**GLA-Fix 1730.10** for UV bonding, stainless steel and designed for glass showcase doors. 16mm base diameter.



**GLA-Fix 1735.10-Shelf support**, for UV bonding, stainless steel and designed for glass showcase shelves. Diameter Ø16mm (5/8") Protection tube, Max. Load 5kg per piece.

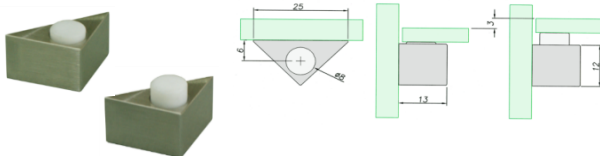

**GLA-Fix 1736.20-Delta Shelf support**, for UV bonding, made of stainless steel and designed for glass showcase shelves. Height adjustment ± 3mm by setscrew.

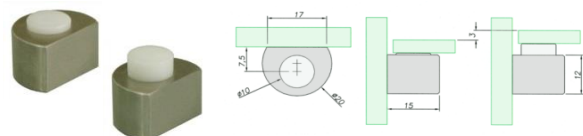

**GLA-Fix 1736.10- Round Shelf support**, for UV bonding, made of stainless steel and designed for glass showcase shelves. 20mm diameter, Height adjustment ± 3mm by setscrew.

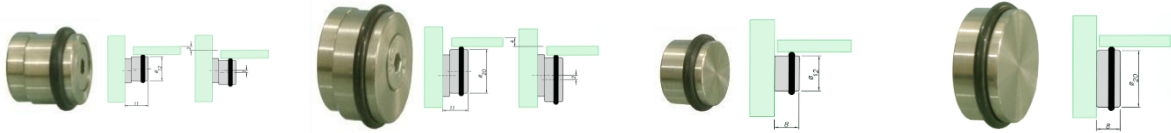

**GLA-Fix Eccentric Shelf support**, for UV bonding, made of stainless steel and designed for glass showcase shelves.  
**1737.20** - 12mm diameter, Eccentric height adjustment  $\pm 1$ mm  
**1737.40** - 20mm diameter, Eccentric height adjustment  $\pm 2$ mm

**GLA-Fix Round Shelf support**, for UV bonding, made of stainless steel and designed for glass showcase shelves.  
**1737.10** - 12mm diameter, with rubber ring  
**1737.30** - 20mm diameter, with rubber ring

**GLA-Fix Bolt Lock**, for UV bonding, made of stainless steel and designed for glass showcase doors.

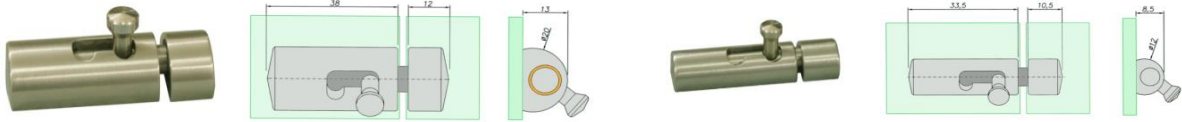

**1740.10**- Big Glass-to-Glass,  $\varnothing 20$ mm

**1740.11**- Small Glass-to-Glass,  $\varnothing 12$ mm

**GLA-Fix Flat Lock**, for UV bonding, made of stainless steel and designed for glass showcase doors. Three applications for Double, inset and overlay doors. Can be bonded for left and right side. Glass thickness; 6-10 mm.

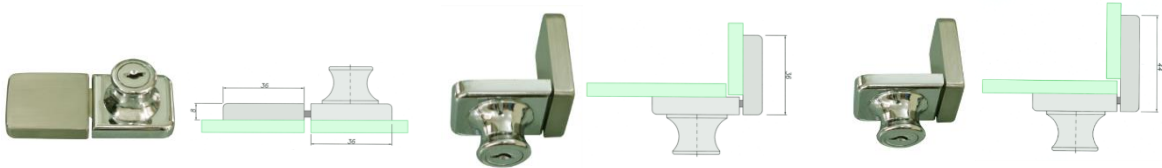

**1741.10**- Double door

**1741.11**- Single inset door

**1741.12**- Single overlay door

**GLA-Fix Tube Lock**, for UV bonding, made of stainless steel and designed for glass showcase doors. Easy to install, All key tubes measure  $\varnothing 30$ mm diameter, and 33mm length. Three applications for Double, inset and overlay doors. Can be bonded for left and right side. Glass thickness; 6-10 mm.

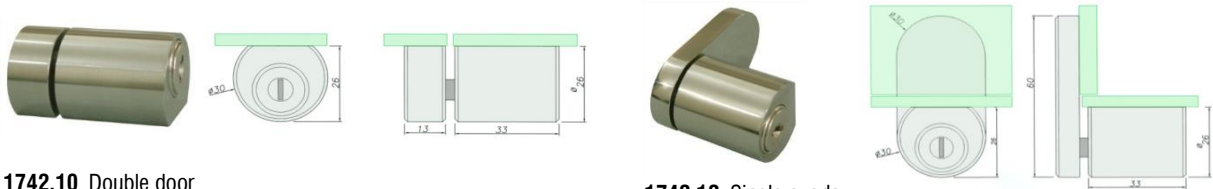

**1742.10** Double door

**1742.12** Single overlay

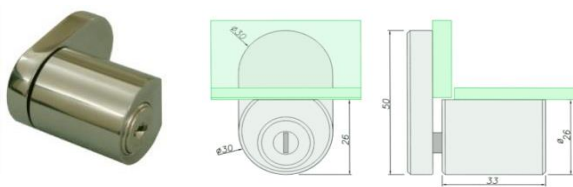

**1742.11** Single inset door

**GLA-Fix Adjustable foot**, for UV bonding, made of Aluminium, designed for glass showcase and furniture. Adjustable height.



**1750.10** Big foot,  
Diameter;  $\varnothing 60$ mm,  
Height; 40-50mm

**1750.11** Small foot,  
Diameter;  $\varnothing 40$ mm,  
Height; 33-41mm

**GLA-Fix Magnetic Latch**, for UV bonding, made of stainless steel and designed for glass showcase doors. Can be bonded to top or bottom of glass showcase and perfectly keeps the door closed. Each latch comes with 12mm round magnetic disc. Two Latches are bonded for double doors.



**1755.11** Double door Magnetic Latch



**1755.10** Single door Magnetic Latch

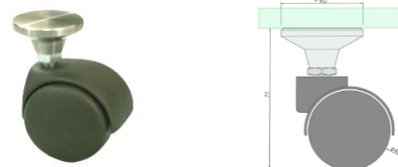
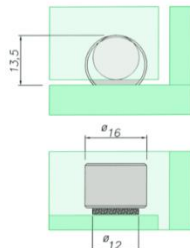

**GLA-Fix 1752.10-Castor Roller**, for UV bonding, Stainless steel bonding base  $\varnothing 40$ mm, designed for glass showcase base. Plastic roller  $\varnothing 40$ mm diameter. Height 71mm.